

ITEM NO	PART NUMBER	DESCRIPTION	VENDOR	VENDORNNO	REV	QTY.
1	01-01_BT	LEFT BOX HALF			A	1
2	01-02_BT	RIGHT BOX HALF			A	1
3	01-03_BT	PLUG ROD	MCMASTER CARR	1263K193	A	1
4	01-04_BT	SPRING ROD			A	1
5	01-05_BT	BOTTOM PLATE			A	1
6	SP-01_BT	STICKER			A	1
7	O-RING .07IN .301IN D	O-RING .07" THICK .301" ID	MCMASTER CARR	9452K19		8
8	SPRING .72IN D 3IN	SPRING .72" DIA 3" LONG	MCMASTER CARR	9657K437		1
9	FHCS 8-32 .375IN	FHCS 8-32 .375" 100 DEGREE	MCMASTER CARR	90729A211		4
10	SHCS 6-32 1.125IN	SHCS 6-32 1.125"	MCMASTER CARR	92196A154		4

REVISIONS				
Rev	Description	DrawnBy	CheckedBy	Date
A	Initial Release	TWS	RN	6/1/20

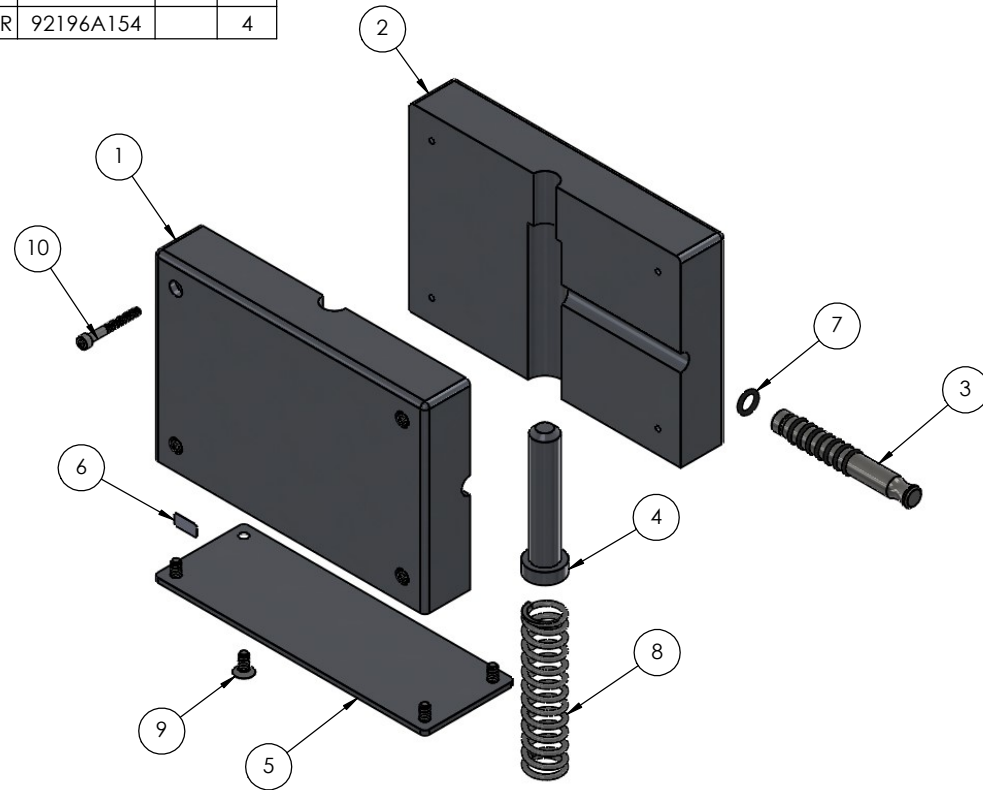

<b>PROPRIETARY AND CONFIDENTIAL</b> THE INFORMATION CONTAINED IN THIS DRAWING IS THE SOLE PROPERTY OF UNIVERSITY OF IDAHO, ME DEPARTMENT. ANY REPRODUCTION IN PART OR AS A WHOLE WITHOUT THE WRITTEN PERMISSION OF UNIVERSITY OF IDAHO, ME DEPARTMENT IS PROHIBITED.		DIMENSIONS ARE IN INCHES THIRD ANGLE PROJECTION		PROJECT TITLE: <b>Block Table</b>	
DEFAULT TOLERANCES: LINEAR: X.±.25 X.X±.1 X.XX±.01 X.XXX±.002		ANGULAR: X.±2 X.X±1 X.XX±0.30'		UNIVERSITY OF IDAHO ME DEPARTMENT	
DESCRIPTION: BOX		FILE NAME/PART NUMBER: 01-00_BT		SHEET: 1 OF 1 SCALE: 1:3	
				REVISION: <b>A</b>	